

PP Ball Valves

Performance™ Series

Description

- Polypropylene Ball Valves for PE pressure piping applications.

Tube

- IPS (OD)
 - For use on HDPE Pipe SDR 7.3 thru SDR 17. Sizes 1/2" - 2" (Blue Body)
 - For use on Sch 40/80 PVC Pipe with SS Gripper Ring. Sizes 1/2" - 2" (Blue Body)
- CTS (OD)
 - For use on Certified PE Pipe SDR 9 & SDR 11. Sizes 3/4" - 2" (Copper Body)
 - For use on Cross Linked Pipe PE SDR 9 for Cold Water Only. Sizes 3/4" - 2" (Copper Body)
 - For use on Copper Pipe with CTS SS Gripper Ring. Sizes 3/4" - 1" (Copper Body)

Working pressure

- Pressure rating: 200 PSI @ 73° F (23° C)

Features

- Compression (IPS & CTS) & Threaded (NPT Male & Female) end connectors available.
- Fully serviceable.
- EPDM O-Rings.
- 100% hydro tested prior to leaving the factory.
- Extremely smooth handle operation.
- UV stabilized.
- Extensively used worldwide.
- ISO 9001 certified.
- Handles available in purple for Reclaim applications.

Applications

- Water distribution
- Reclaim water
- Industrial
- Leachate Collection
- Irrigation
- Many other uses



Ball Valves Pressure Loss

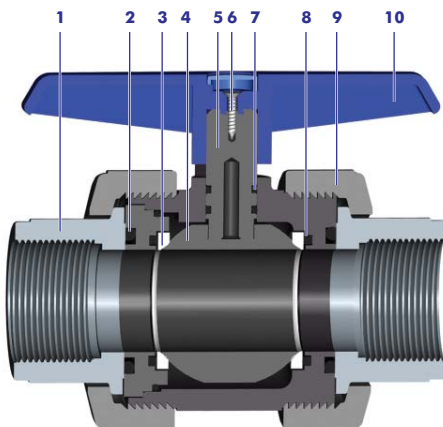
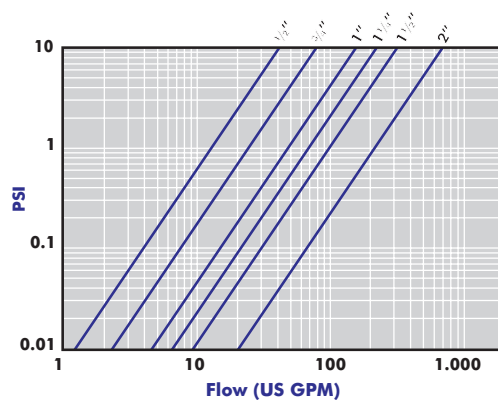

Parts

N°	Description	Material	N° Req.
1	End Connector	PP	2
2	End Connector O-Ring	EPDM	2
3	Seat	PE	2
4	Ball	PVC	1
5	Stem	PVC	1
6	Fastening Screw	Stainless Steel	1
7	Stem O-Ring	EPDM	2
8	Body O-Ring	EPDM	2
9	Nut	PP	2
10	Handle	PP	1